



LOUVREKIT

LouvreKit Design Manual

18367
REV5
MARCH 2023

DOCUMENT STATUS

The most recent version of this document (revision 4), as detailed in the document history, is approved by Richards Consulting Engineers. It is effective from 20th of October and supersedes all previous version of this document.

Document Revision	Date	Alterations
Revision 3	09/2020	Change to post size
Revision 4	22/01/2021	Addition of corner gusset to allow screens to be installed on the louvrekit
Revision 5	10/03/2023	Addition of second bay option

JOHNSON & COUZINS LOUVREKIT LOUVRE SYSTEM

Johnson & Couzins have developed an opening louvre system for use in New Zealand. The system is manufactured out of aluminium and consists of a perimeter RHS frame with louvre fins spanning in one direction loading up the frame members. The louvre roof is supported on aluminium SHS posts. The posts cantilever from their footings.

Richards Consulting Engineers Limited has been engaged by Johnson and Couzins to prepare standard design tables and template details to assist with the design of the LouvreKit Louvre System.

DESIGN PHILOSOPHY

The following design flow chart, design tables and calculations have been designed using wind speeds taken from NZS3604:2011 and with open ground snow load of 0.9 kPa, 1.5 kPa and 2.0 kPa. The wind speeds shown in the tables are the Ultimate Limit State (ULS) design wind speeds. The associated pressures specific to the louvre fins and frame structure were calculated using AS/NZS 1170.2:2011, Structural Design Actions, Part 2: Wind Actions. The sectional capacities of the aluminium and stainless steel members have been determined using Aluminium Structures, Part 1: Limit State Design AS/NZS 1664.1:1997 and Steel Structures Standard, NZS3404: Part 1: 1997 respectively.

The louvre's lateral load resisting system will be provided by cantilevering posts and will not be attached to any other structures.

The design of the louvre structure based on the tables within this document is in compliance with the New Zealand Building Code (NZBC) section B1.

SERVICEABILITY CRITERIA

The following deflection limits were used for the following elements within the Louvre System:

- 10mm maximum perimeter and deflections under gravity loading
- 60mm maximum louvre fin deflections
- 100mm maximum lateral deflection of louvre frame support posts

DESIGN LOADS AND LOAD CASES

The Ultimate Limit State wind speeds taken from NZS3604:2011 are as follows:

- Medium wind speed = 37 m/s
- High wind speed = 44 m/s
- Very high wind speed = 50m/s

The following design load cases have been applied to the louvre fins and frame members:

- 0.9G + Wu (ULS for wind uplift)
- 1.2G + S (ULS downward load case)
- 1.2G + 1.5Q (ULS downward load case)
- Ws (SLS for wind related deflection)
- G + φ_s Q (SLS for live load deflection)

Note: Earthquake cases do not govern due to the lightweight properties of the louvre system.

DESIGN LIMITATIONS

The following design assumptions apply to the design manual:

- The louvres will not be walked on
- The pitch of the louvre frame is less than 10 degrees
- The supporting frame has a maximum height of 2.7m
- Standard Johnson & Couzins connections will be used
- The Louvre will be installed in accordance with the Johnson & Couzins instruction manual.

DESIGN EXCLUSIONS

The following items are specifically excluded from this design manual:

- Weather and waterproofing of both the louvre and the supporting structure
- Electronic services to the louvre
- Connections within the Johnson and Couzins louvre system
- Flutter effects caused by wind passing over the open louvres

MATERIAL AND SECTION PROPERTIES

The louvres will be made from aluminium with a 6060 alloy and a T5 temper.

DURABILITY

The louvre system has been designed with an intended design life of not less than 20 years. Aluminum provides adequate durability for the life of the structure. All contact points between differing materials (Aluminium – Stainless Steel, Aluminium – Galvanised Steel and Galvanised Steel – Stainless Steel) shall have a grease barrier applied to them to prevent galvanic corrosion from occurring. The surfaces which the aluminum posts are fixed to are to be 225mm above adjacent unfinished ground surfaces (E1).

The aluminium shall be powder coated in all areas (including other corrosive environments and sea spray zone) in Dulux Duralloy. For when the louvre will be located within the sea spray zone (as defined in NZS3604:2011) the maintenance schedule below shall be followed to ensure the design life of the louvre is reached.

Inspection/Maintenance timeframe and item	
(a) Half-yearly	Wash down louvre frame.
(b) 5-yearly	Inspect and if required repair regrease barrier between fixings
(c) 10-yearly	Check all aspects of the louvre frame for damage and corrosion – replace elements if required

There are three components required for corrosion to occur. An anode, a cathode and an electrically conductive liquid. In the case of the louvres, the anode is the aluminium and the cathode is the stainless or galvanised steel. It is the anode which corrodes sacrificially and therefore it is the aluminium which is at risk of corrosion, not the steel. A large anode with a small cathode such as a steel fixing into the louvre frame is low risk for corrosion due to the small area of the steel cathode relative to the aluminium. The connection of the flashings (steel) and the aluminium louvre is the potential area of concern for corrosion to occur, however, both the louvre frame and the flashings are powder coated. We consider the aluminium combined with powder coating provides sufficient protection between the two metal types to prevent galvanic corrosion occurring over the proposed 20 year design life.

We note that there is no effective verification method for B2 contained within the Building Code. However, we confirm that we have researched the corrosive effects between aluminium and other dissimilar metals and consider a minimum design life of 20 years to be appropriate provided the aluminium is powder coated and the grease barriers are applied to the metals.

DESIGN MANUAL NOTES

It is intended this manual will be used by people experienced with the Johnson & Couzins LouvreKit Louvre System. The louvre designer shall:

- Design the louvre layout within the maximum spans set out in the enclosed tables.
- Only the attached connection details shall be used.
- No substitution with the products included in this are permitted.
- Where the louvre does not fit within the design manual criteria a Structural Engineer shall be engaged to specifically design the louvre.

APPENDICIES

- PS1
- Design Tables
- Details



PRODUCER STATEMENT – PS1 DESIGN

BUILDING CODE CLAUSE(S): B1 only
ISSUED BY: Richards Consulting Engineers Limited
(Engineering Design Firm)

JOB NUMBER: 18367

TO: Johnson and Couzins 2000 Limited
(Owner/Developer)

TO BE SUPPLIED TO: All territories within New Zealand
(Building Consent Authority)

IN RESPECT OF: Johnson and Couzins 200 Limited standard design tables for the louvrekit system
(Description of Building Work)

AT:
(Address, Town/City)

LEGAL DESCRIPTION: N/A

We have been engaged by the owner/developer referred to above to provide (Extent of Engagement):
Johnson and Couzins 200 Limited standard design tables for the louvrekit system
in respect of the requirements of the Clause(s) of the Building Code specified above for Part only, as specified in
the Schedule, of the proposed building work.

The design carried out by us has been prepared in accordance with:

- Compliance documents issued by the Ministry of Business, Innovation & Employment (Verification method/acceptable solution) B1/VM1 and/or;
- Alternative solution as per the attached Schedule.

The proposed building work covered by this producer statement is described on the drawings specified in the Schedule, together with the specification, and other documents set out in the Schedule.

On behalf of the Engineering Design Firm, and subject to:

- Site verification of the following design assumptions: N/A
- All proprietary products meeting their performance specification requirements;

I believe on reasonable grounds that:

- the building, if constructed in accordance with the drawings, specifications, and other documents provided or listed in the Schedule, will comply with the relevant provisions of the Building Code and that;
- the persons who have undertaken the design have the necessary competency to do so.

I recommend the **CM0** level of **construction monitoring**.

I, (Name of Engineering Design Professional) Chris Burrell-Smith, am

- CPEng number 1019482
and hold the following qualifications BE(Hons)

The Engineering Design Firm holds a current policy of Professional Indemnity Insurance no less than \$200,000
The Engineering Design Firm is a member of ACE New Zealand.

SIGNED BY (Name of Engineering Design Professional): Chris Burrell-Smith
(Signature below)

ON BEHALF OF (Engineering Design Firm): Richards Consulting Engineers Limited

Date: 06/03/2023

Note: This statement has been prepared solely for the Building Consent Authority named above and shall not be relied upon by any other person or entity. Any liability in relation to this statement accrues to the Engineering Design Firm only. As a condition of reliance on this statement, the Building Consent Authority accepts that the total maximum amount of liability of any kind arising from this statement and all other statements provided to the Building Consent Authority in relation to this building work, whether in tort or otherwise, is limited to the sum of \$200,000.

This form is to accompany **Form 2 of the Building (Forms) Regulations 2004** for the application of a Building Consent.

SCHEDULE TO PS1

Please include an itemised list of all referenced documents, drawings, or other supporting materials in relation to this producer statement below:

Johnson and Couzins Louvrekit Design Manual

LOUVREKIT SINGLE BAY OPTION

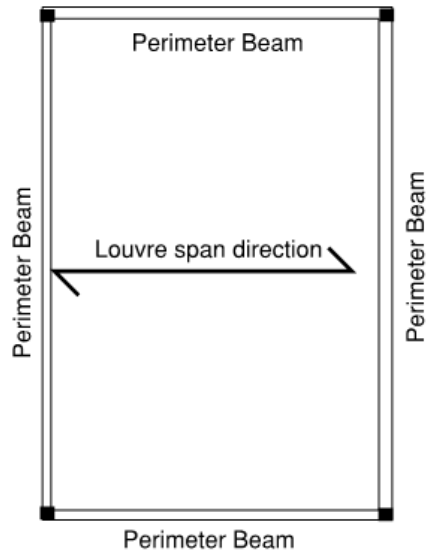

LOUVREKIT TWO BAY OPTION

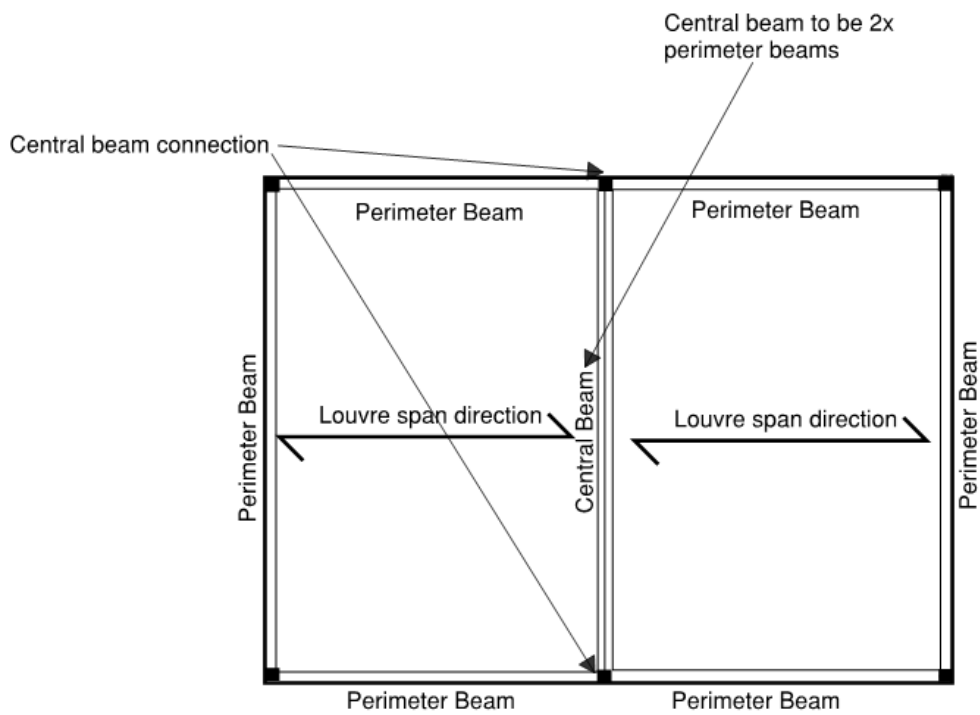

LOUVRE FIN SPANS

Table 1 – Johnson & Couzins Maximum LouvreKit Fin Spans

Louvre Fin Type	Medium wind zone (37m/s)	High wind zone (44 m/s)	Very High wind zone (50 m/s)
Louvre	3.4 m	3.0 m	2.8 m

Notes:

1. Site wind speed is to be verified by others.
2. Includes allowance to resist up to 2.0 kPa open ground snow load.
3. A maximum louvre fin deflection of 60mm has been used. Specific Engineering Design is required for louvres which will be located within areas sensitive to deflections.
4. All spans shown above are maximum values.
5. It has been assumed that the louvres will remain in an “open” position during a heavy snow event.
6. The louvre fins will not be walked on.
7. The fin span is measured from between the inside edges of the drive boxes.

LOUVREKIT FRAME MEMBER SPANS

General Notes:

1. Site wind speed is to be verified by others.
2. Perimeter beam supports half of the louvre span while a central beam supports louvres on both sides.
3. Spans calculated rely on correct selection of louvre fin.
4. A maximum beam deflection limit of 40mm has been used for members.
5. All spans shown below are maximum values and are measured from the inside edges of the posts.
6. If the louvre is located right up against the house a reduction factor of 0.8 needs to be applied to the maximum beam span if the open ground snow load is greater than 1.5.
7. We have assumed a drive box will be located adjacent to the beams.
8. No screens will be attached to the louvre
9. The louvre will be located away from any areas where snow may fall from adjacent roofs
10. The central beam is to be made up of two perimeter beams and designed with the following table

Table 2 – Johnson & Couzins Max LouvreKit perimeter Beam (200x50x3 RHS) Span

Open Ground Snow load	Medium wind zone (37m/s)	High wind zone (44m/s)	Very High wind zone (50m/s)
	LouvreKit fin	LouvreKit fin	LouvreKit fin
< 0.9	6.2 m	5.6 m	5.2 m
< 1.5	5.9 m	5.6 m	5.2 m
< 2	5.1 m	5.5 m	5.2 m
> 2	SED	SED	SED

Table Specific Notes:

1. Refer to the “General Notes” for all other notes which are not specific to this particular table.

JOHNSON & COUZINS

LouvreKit

STANDARD DETAILS

STRUCTURAL DRAWING LIST

Job No 18367

DWG No. TITLE

S1.01	DETAILS
S1.02	DETAILS
S1.03	DETAILS



REV 5

MARCH 2023

FOR CONSTRUCTION

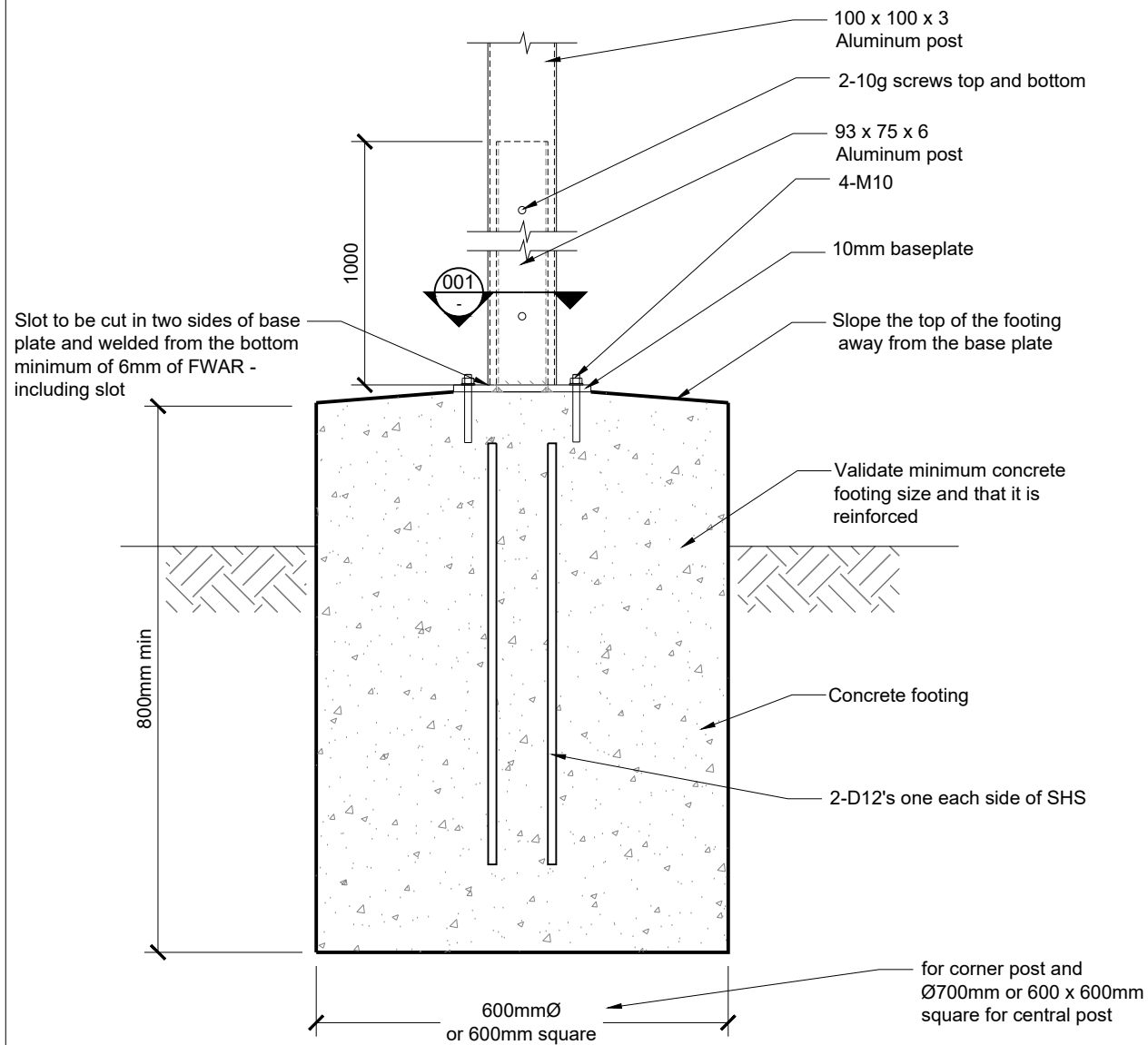

1 POST TO CONCRETE FOOTING
SCALE 1:10

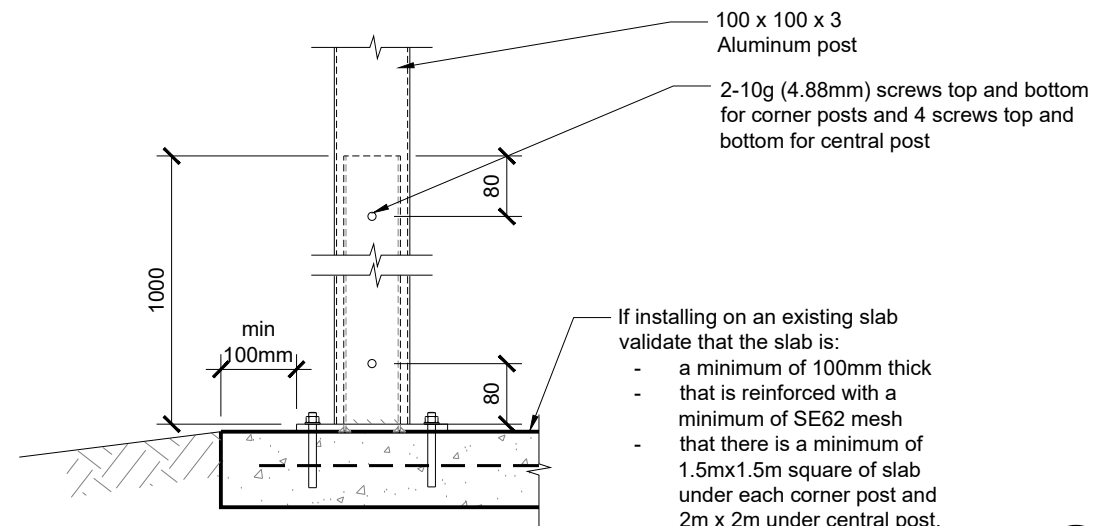

2 POST TO EXISTING OR NEW SLAB FOUNDATION
SCALE 1:10

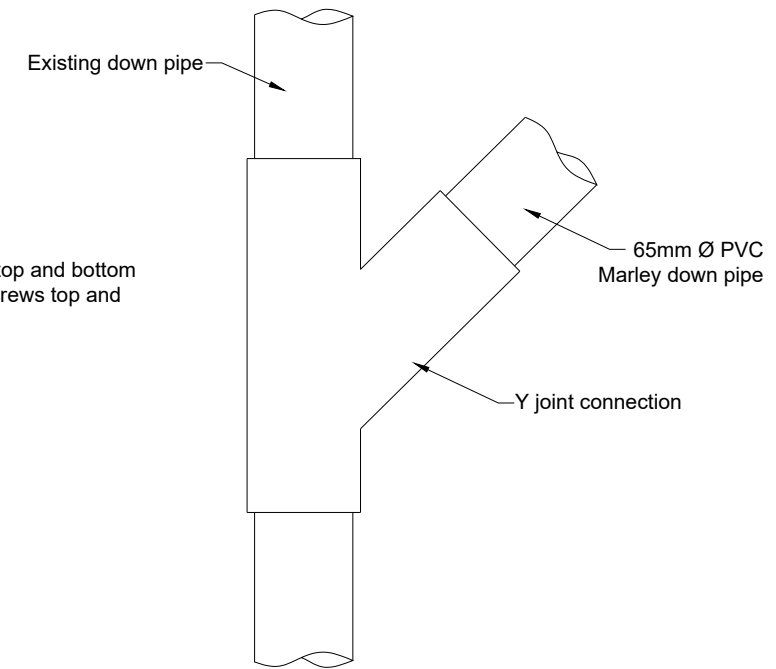

3 Y JOINT CONNECTION
SCALE 1:5

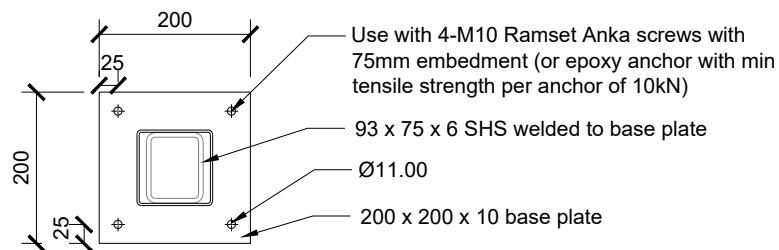

001 BASE PLATE CONNECTION
SCALE 1:10

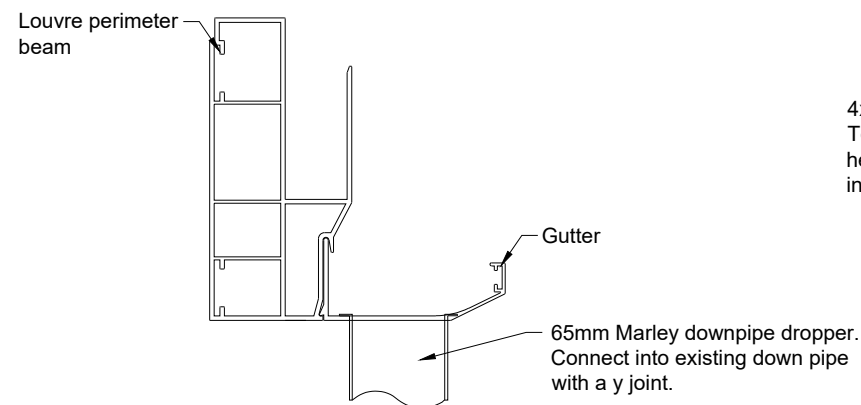

4 STORM WATER CONNECTION
SCALE 1:5

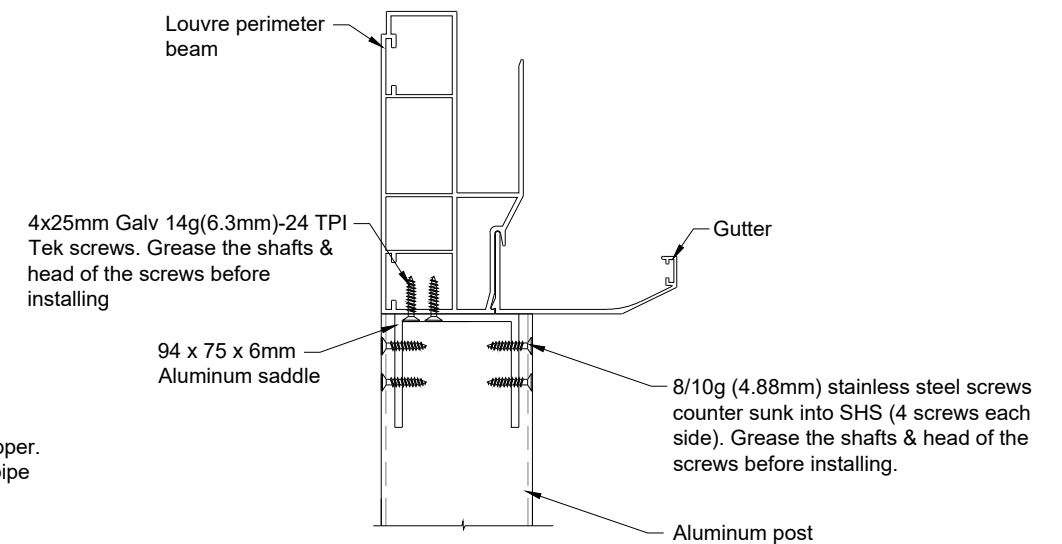

5 CORNER LOUVRE PERIMETER BEAM TO LEG DETAIL
SCALE 1:5

THIS DRAWING IS TO BE READ IN CONJUNCTION WITH ARCHITECT'S DRAWINGS



PROJECT TITLE
JOHNSON & COUZINS
LouvreKit
STANDARD DETAILS

DRAWING TITLE
DETAILS

REV NO.	REVISION	DATE	APPROVED	PROJECT NO.	DESIGNED
1.	FOR CONSTRUCTION	JUL 2018	SR	18367	SR
2.	FOR CONSTRUCTION	SEP 2020	SR	SCALE @ A3	MA
3.	FOR CONSTRUCTION	MAR 2023	SR	REV NO.	SHEET NO.
				3	S1.01

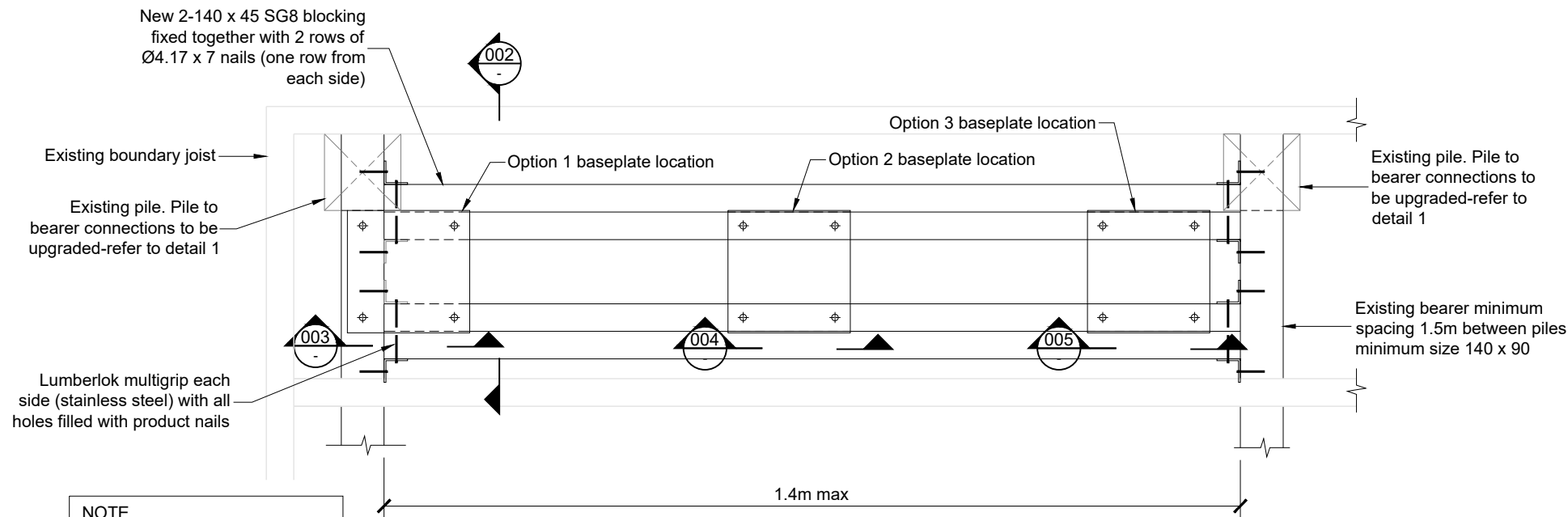

NOTE
If any of the existing conditions of existing deck not met then install new concrete footing

6 LOUVRE POST ON BEARER CONNECTION - PLAN VIEW
SCALE 1:10

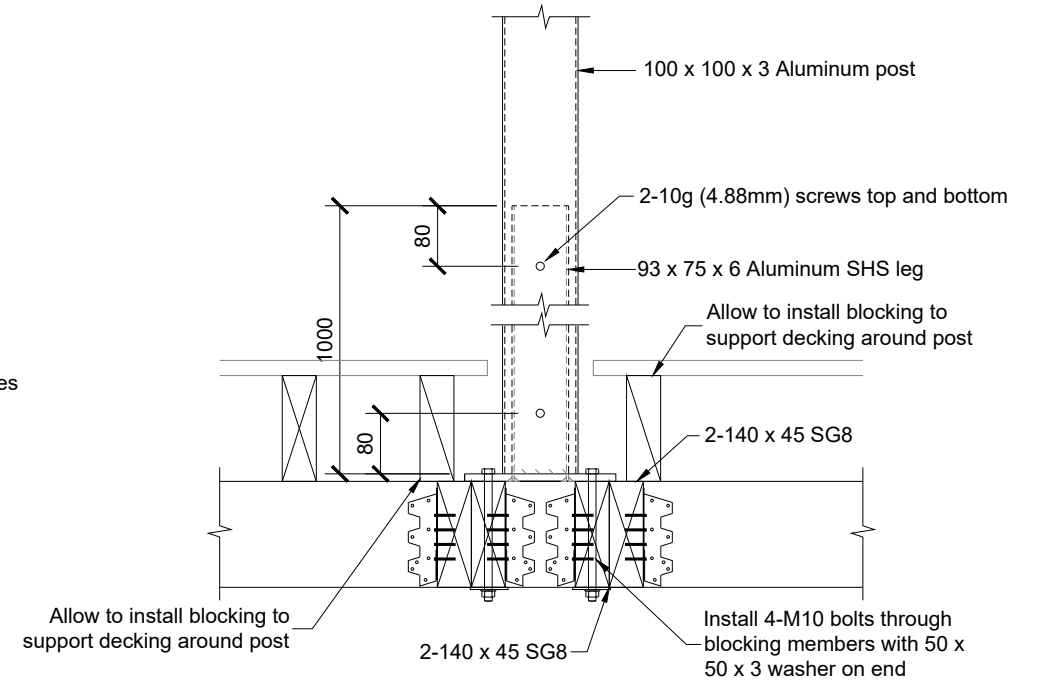

002 LOUVRE POST TO DECK BEARER CONNECTION
SCALE 1:10

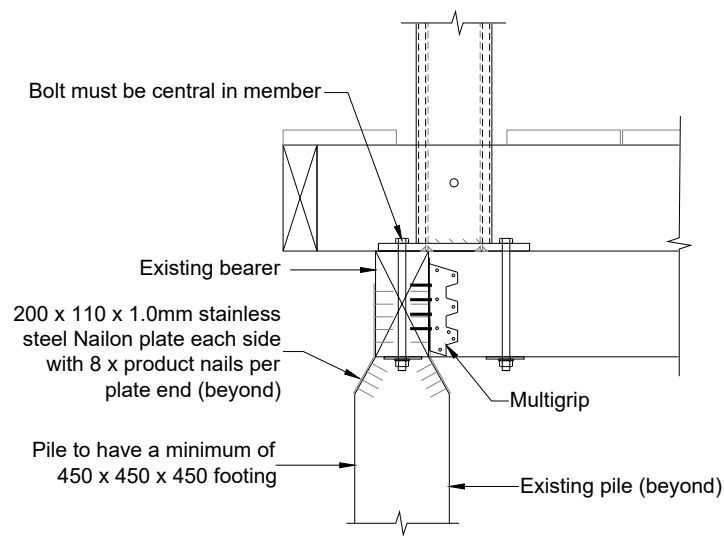

003 LOUVRE POST TO DECK OPTION 1
SCALE 1:10

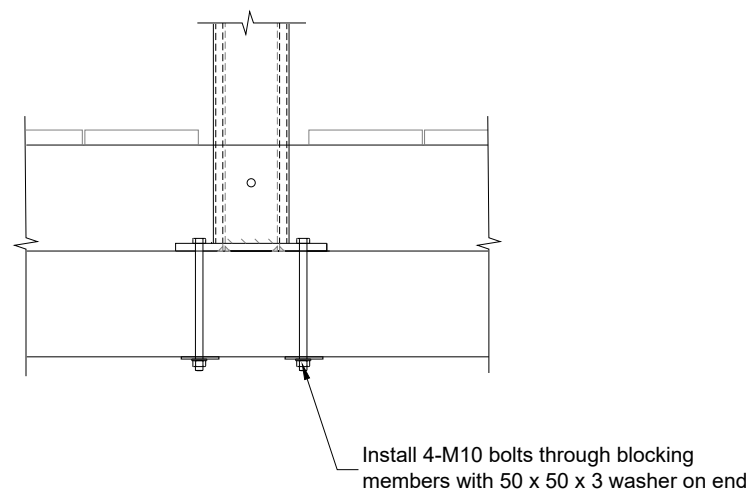

004 LOUVRE POST TO DECK OPTION 2
SCALE 1:10

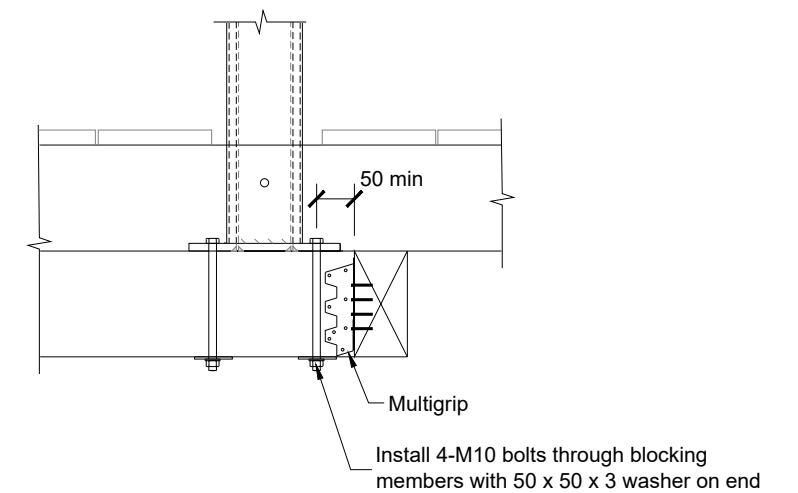

005 LOUVRE POST TO DECK OPTION 3
SCALE 1:10

THIS DRAWING IS TO BE READ IN CONJUNCTION WITH ARCHITECT'S DRAWINGS



PROJECT TITLE
JOHNSON & COUZINS
LouvreKit
STANDARD DETAILS

DRAWING TITLE
DETAILS

REV NO.	REVISION	DATE	APPROVED
1.	FOR CONSTRUCTION	JUL 2018	SR
2.	FOR CONSTRUCTION	OCT 2018	SR
3.	FOR CONSTRUCTION	SEP 2020	SR
4.	FOR CONSTRUCTION	MAR 2023	SR

PROJECT NO.	18367	DESIGNED	SR
SCALE @	A3	DRAWN	MA
REV NO.	4	SHEET NO.	S1.02

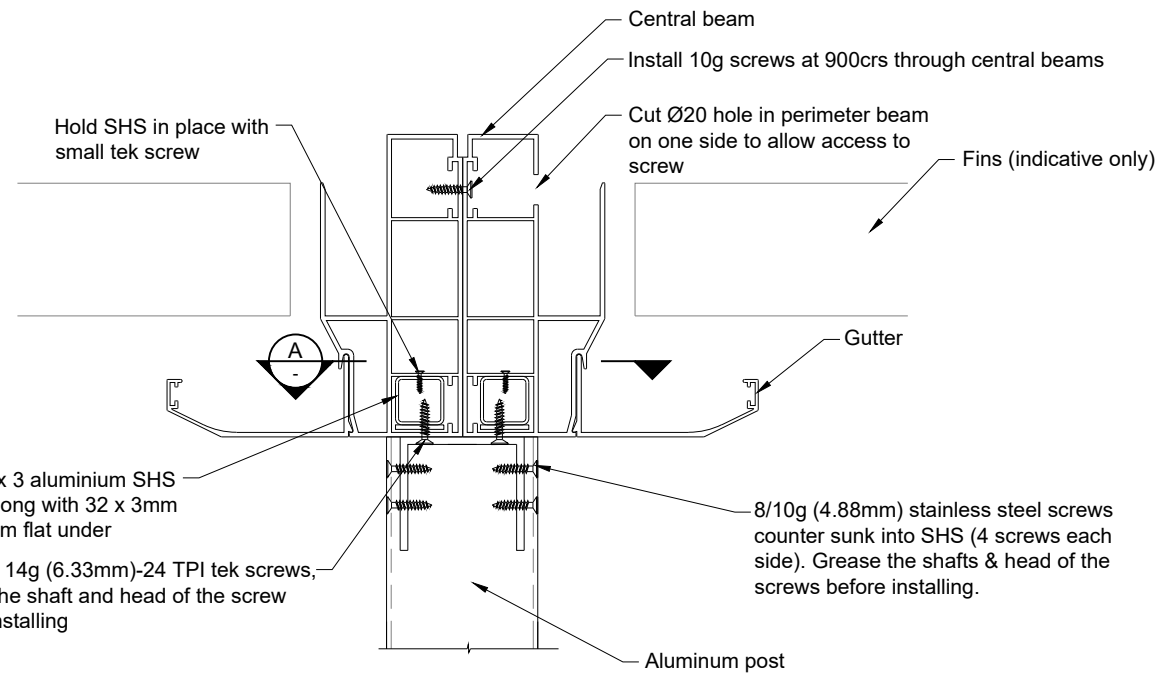

**CENTRAL LOUVRE PERIMETER
BEAM TO LEG DETAIL (fin direction 1)**
SCALE 1:5

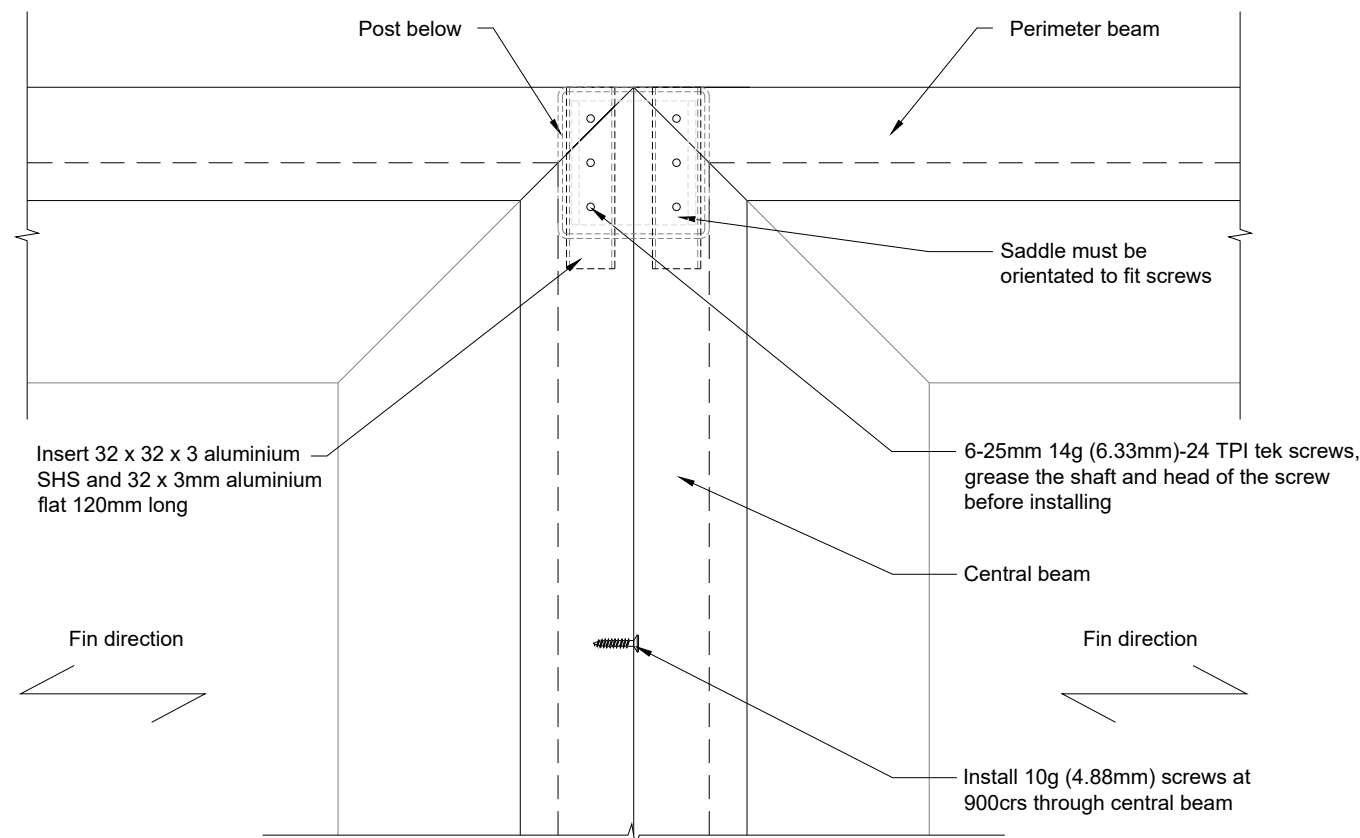

A **CENTRAL LOUVRE PERIMETER
BEAM TO LEG DETAIL (fin direction 1)**
SCALE 1:5

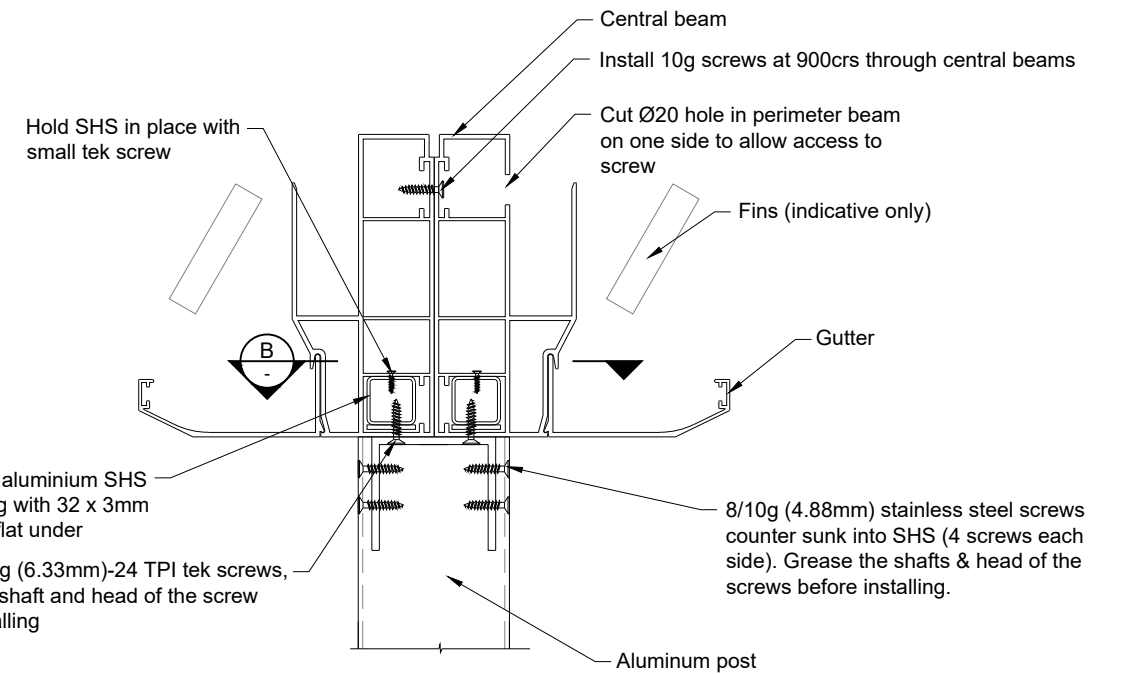

**CENTRAL LOUVRE PERIMETER
BEAM TO LEG DETAIL (fin direction 2)**
SCALE 1:5

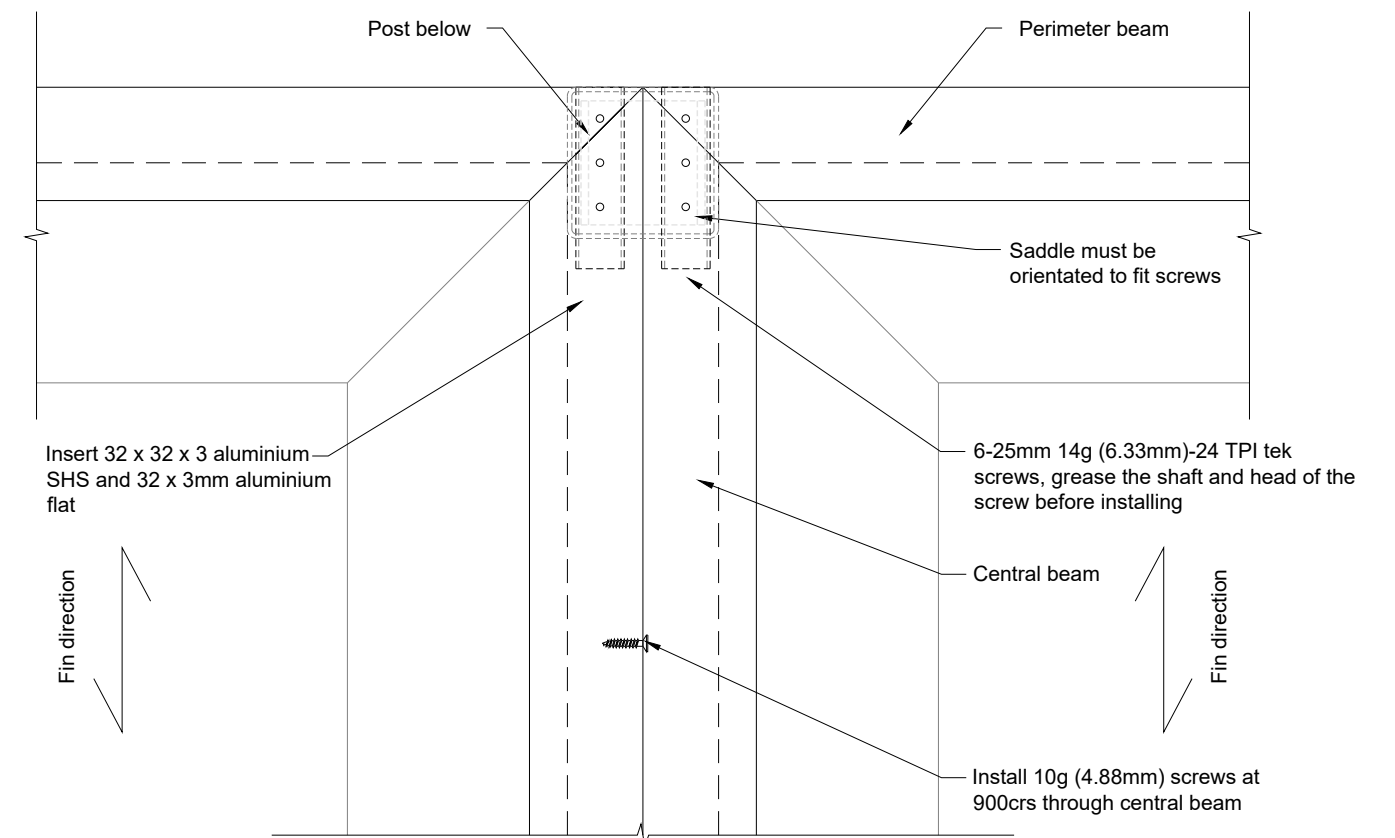

B **CENTRAL LOUVRE PERIMETER
BEAM TO LEG DETAIL (fin direction 2)**
SCALE 1:5

THIS DRAWING IS TO BE READ IN CONJUNCTION WITH ARCHITECT'S DRAWINGS